

Etage Fussgeschoss
Fläche 97.0 m²
Raumhöhe 3.95 m

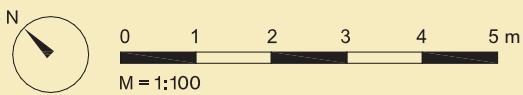

Etage Fussgeschoss
Fläche 123.5 m²
Raumhöhe 3.95 m

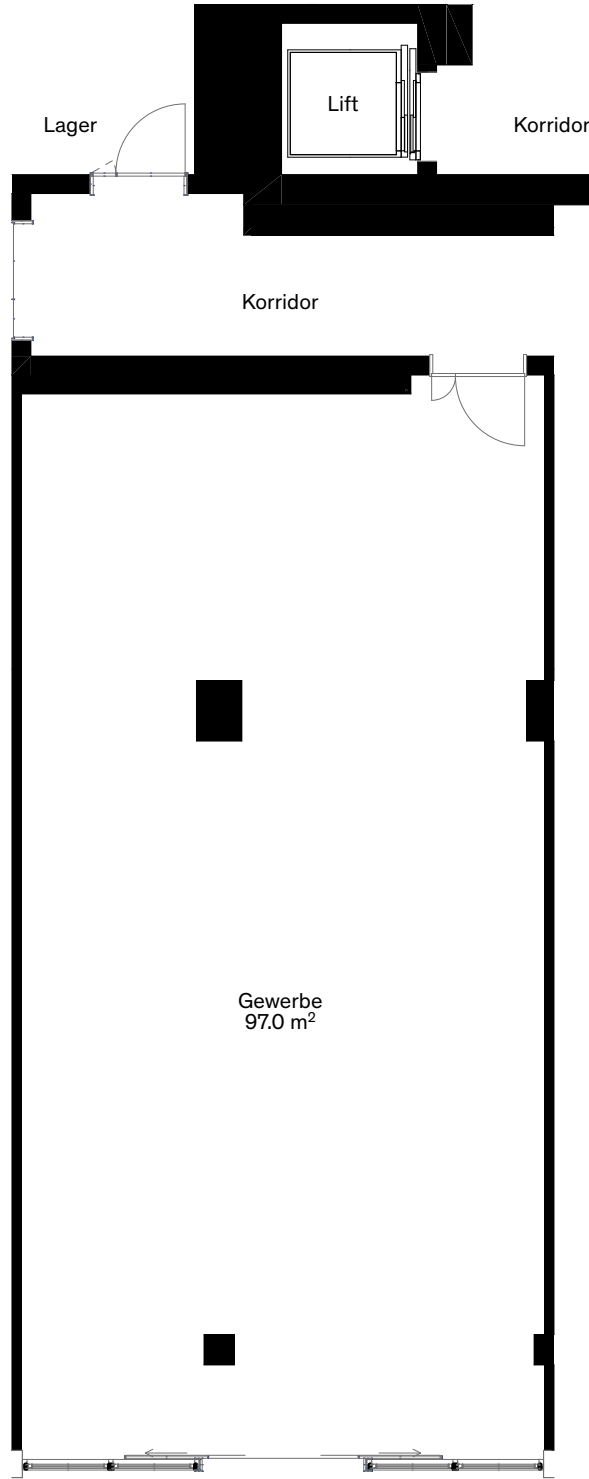
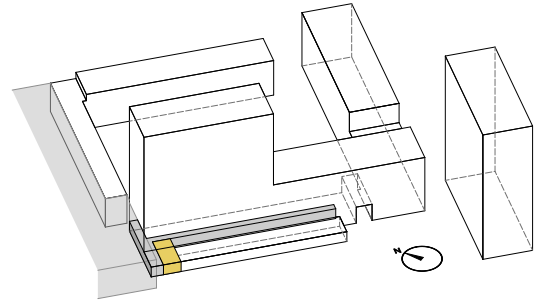
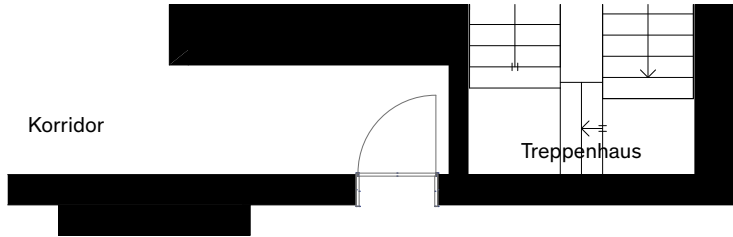
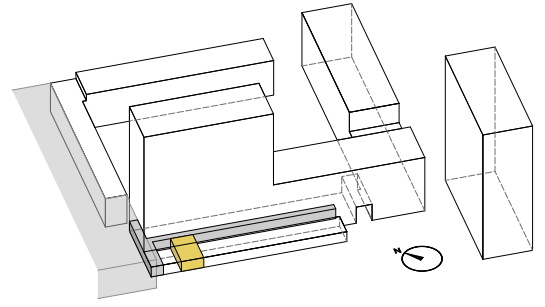

Korridor

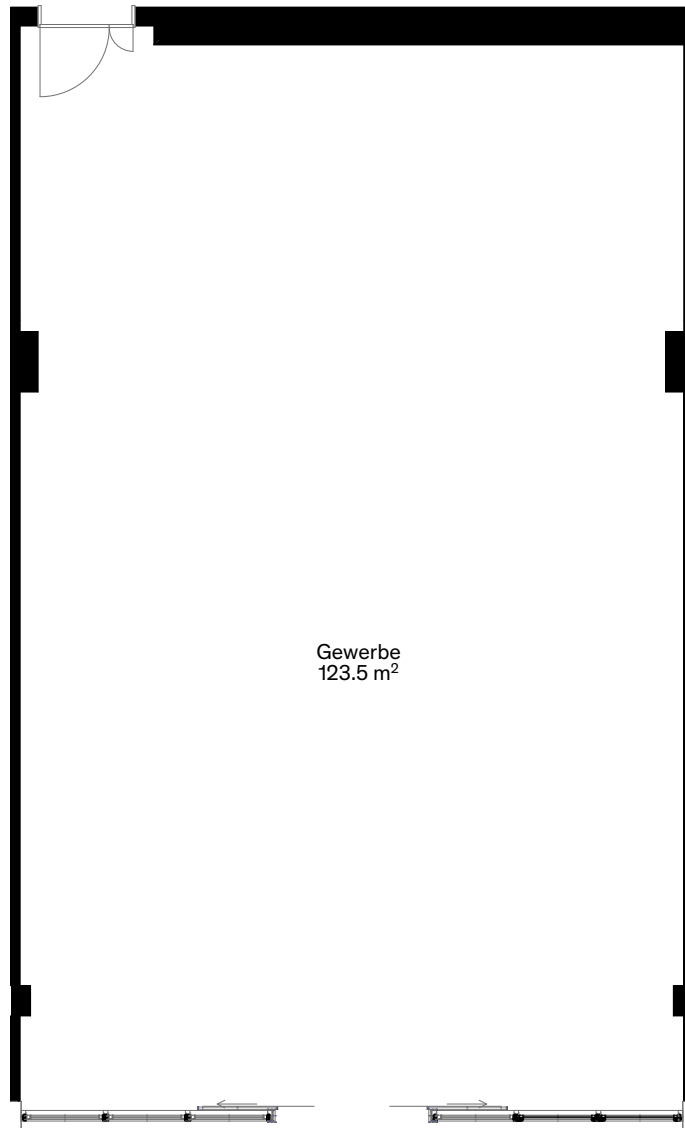

Gewerbe
123.5 m²

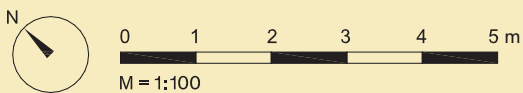

Etage Fussgeschoss
Fläche 123.5 m²
Raumhöhe 3.95 m

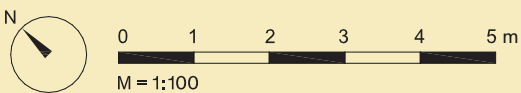
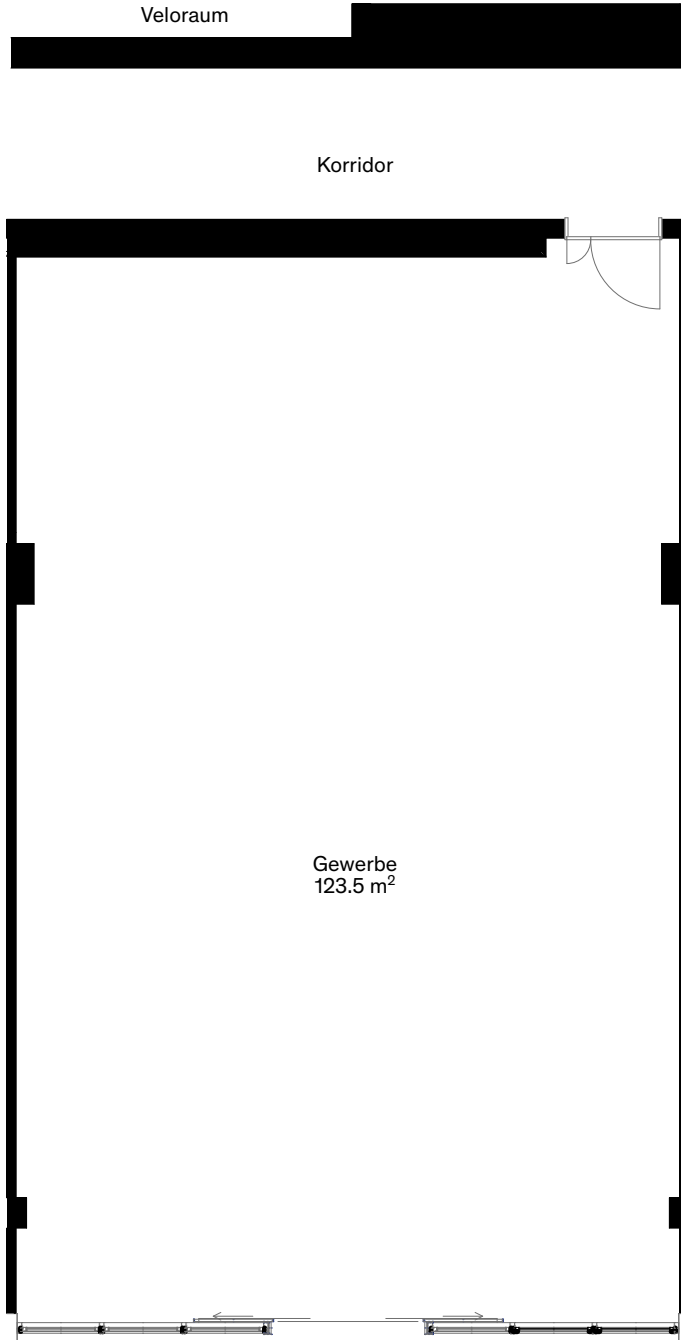
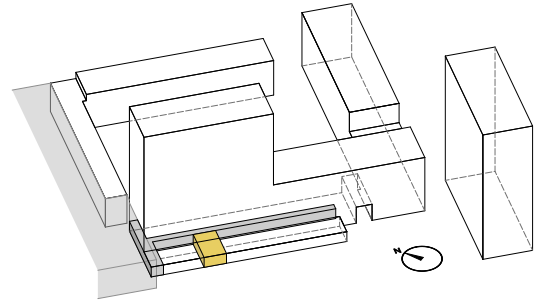

Etage Fussgeschoss
Fläche 123.5 m²
Raumhöhe 3.95 m

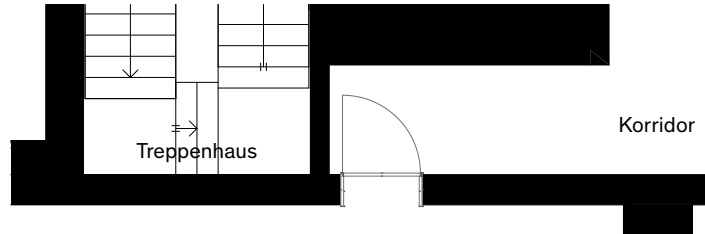
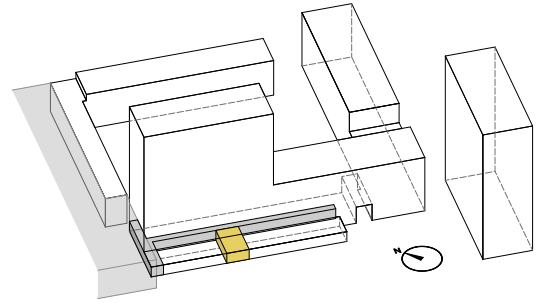

Korridor

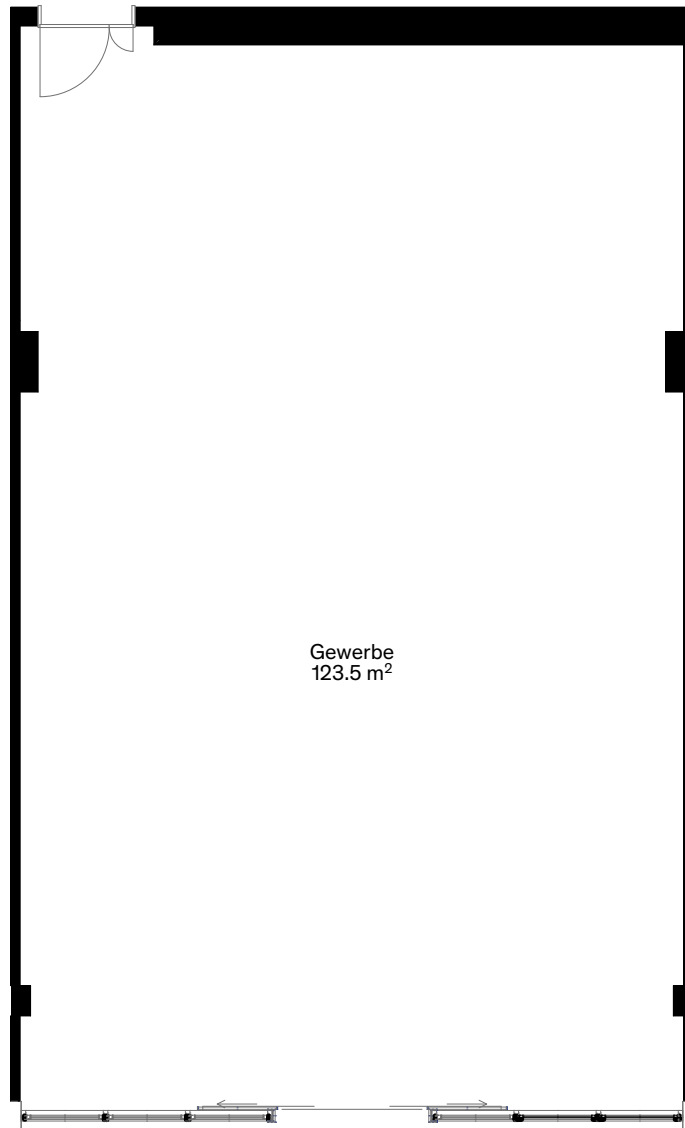

Gewerbe
123.5 m²

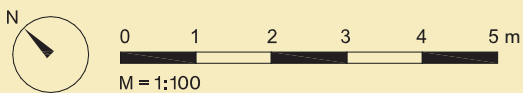

Haus A: Heitersberg Gewerbefläche A0.FG.06

Sandackerstrasse 7a, 8957 Spreitenbach

Etage Fussgeschoss
Fläche 97.0 m²
Raumhöhe 3.95 m

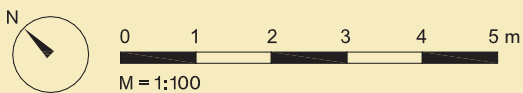
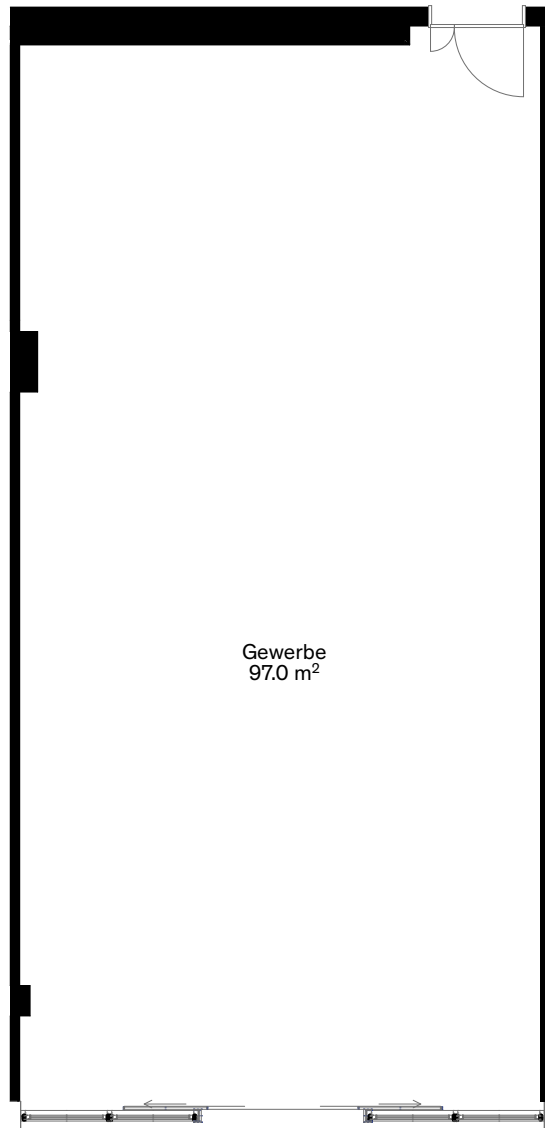
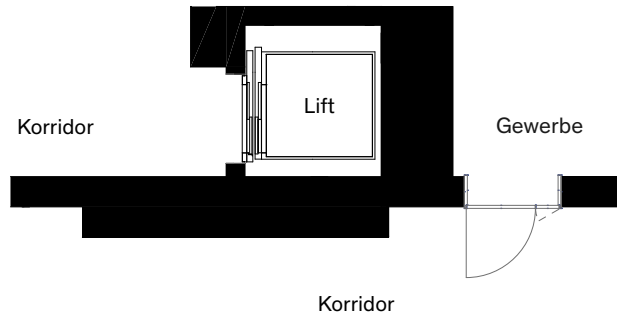
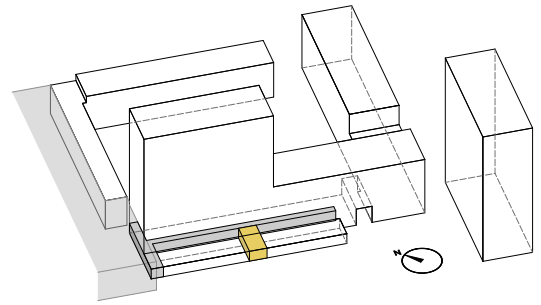

Etage	Fussgeschoss
Fläche	76.5 m ²
Raumhöhe	3.95 m

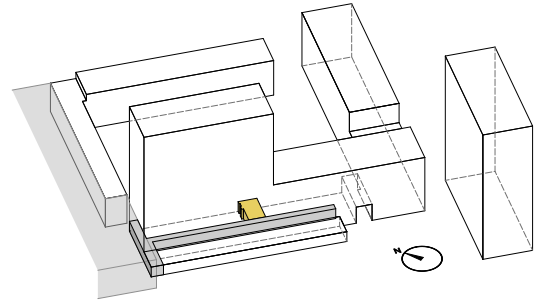

Innenhof

Gehweg

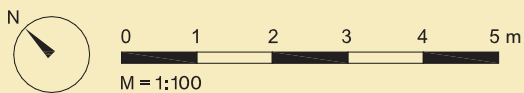
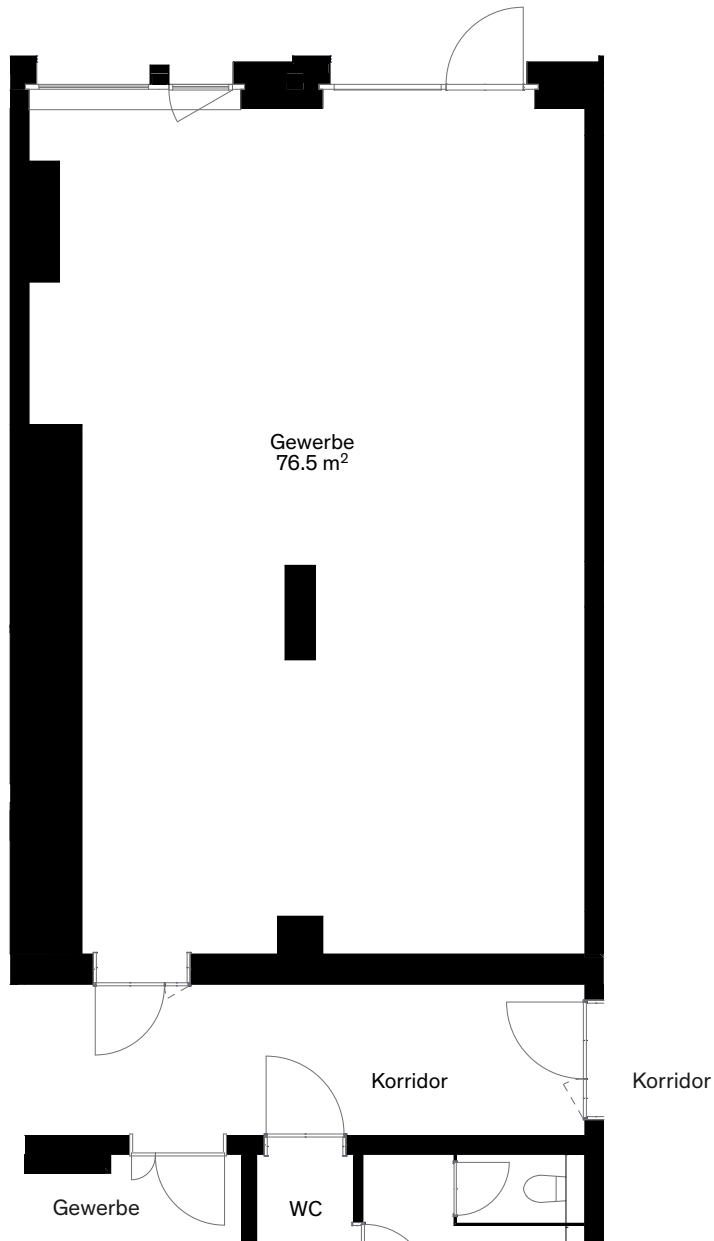

Etage Fussgeschoss
Fläche 192.0 m²
Raumhöhe 3.68 m

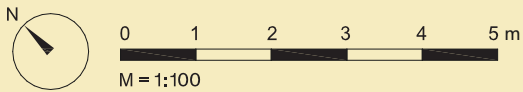
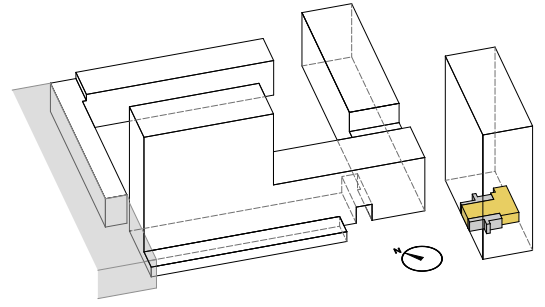

Etage 1. Obergeschoss
Fläche 206.4 m²
Raumhöhe 2.63 m

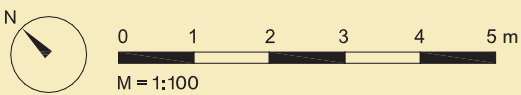
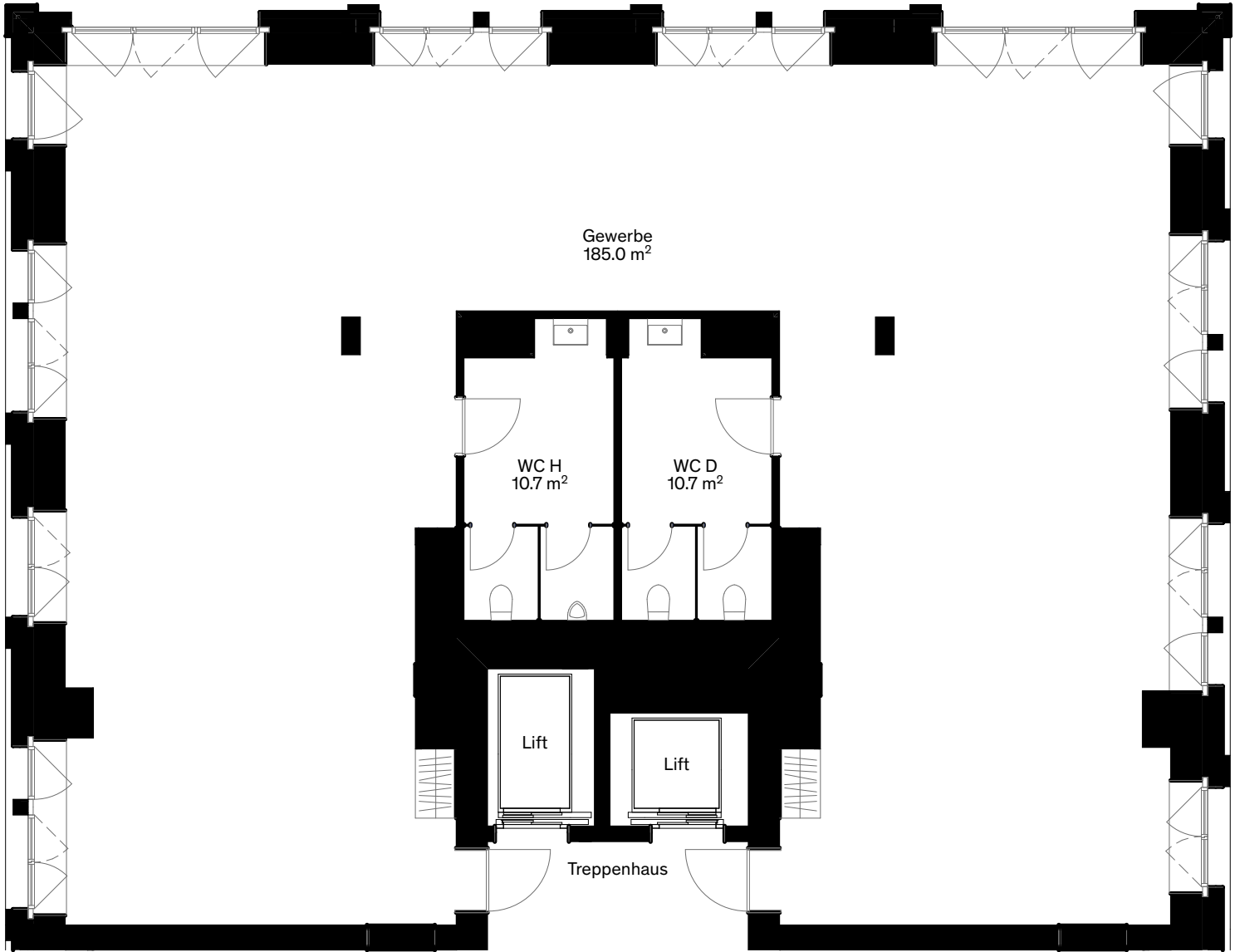
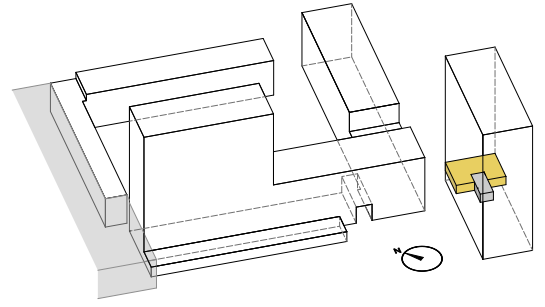

Haus B: Marmorì Turm

Gewerbefläche B1.01.1B

Sandackerstrasse 1b, 8957 Spreitenbach

Etage 1. Obergeschoss
Fläche 146.2 m²
Raumhöhe 2.63 m

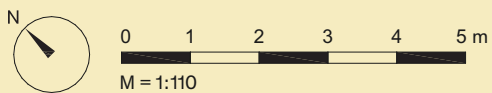
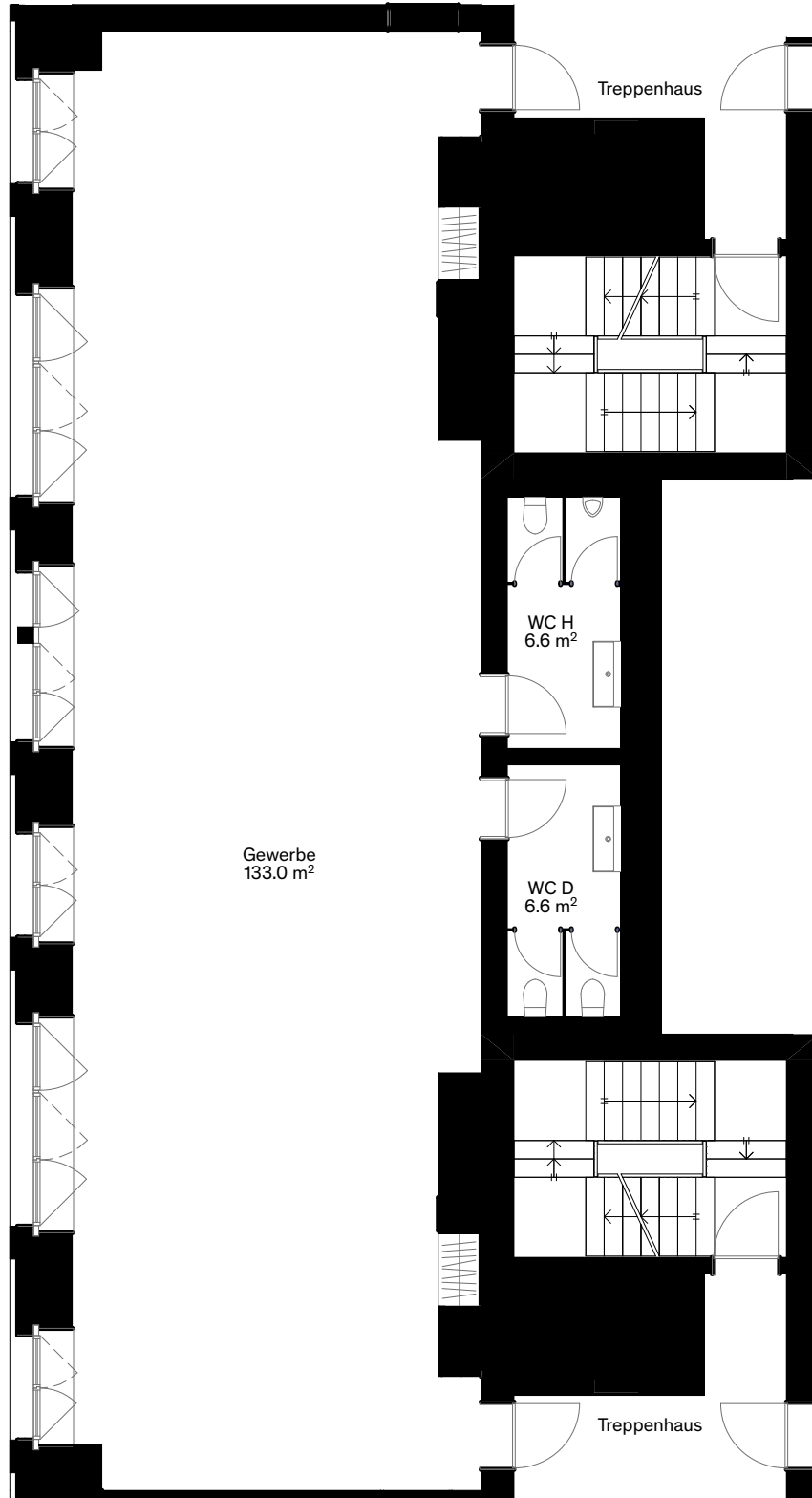
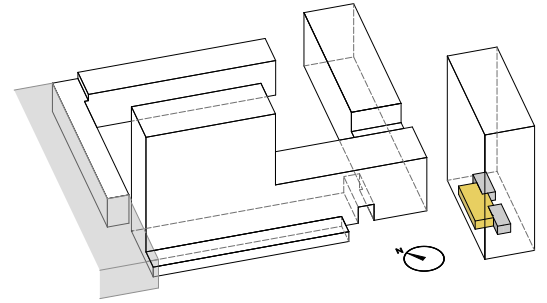

Alle Angaben, Pläne, Zeichnungen usw. sind unverbindlich.
Änderungen bleiben vorbehalten. Stand Mai 2023.

Intercity
Vermarktung

Intercity Vermarktung AG, Zollikerstrasse 141, 8008 Zürich
T +41 44 388 58 80, tivoli-garten@intercity.ch, www.tivoli-garten.ch

Etage 1. Obergeschoss
Fläche 144.2 m²
Raumhöhe 2.63 m

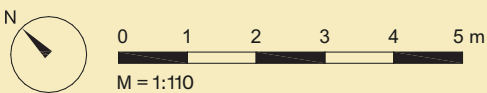
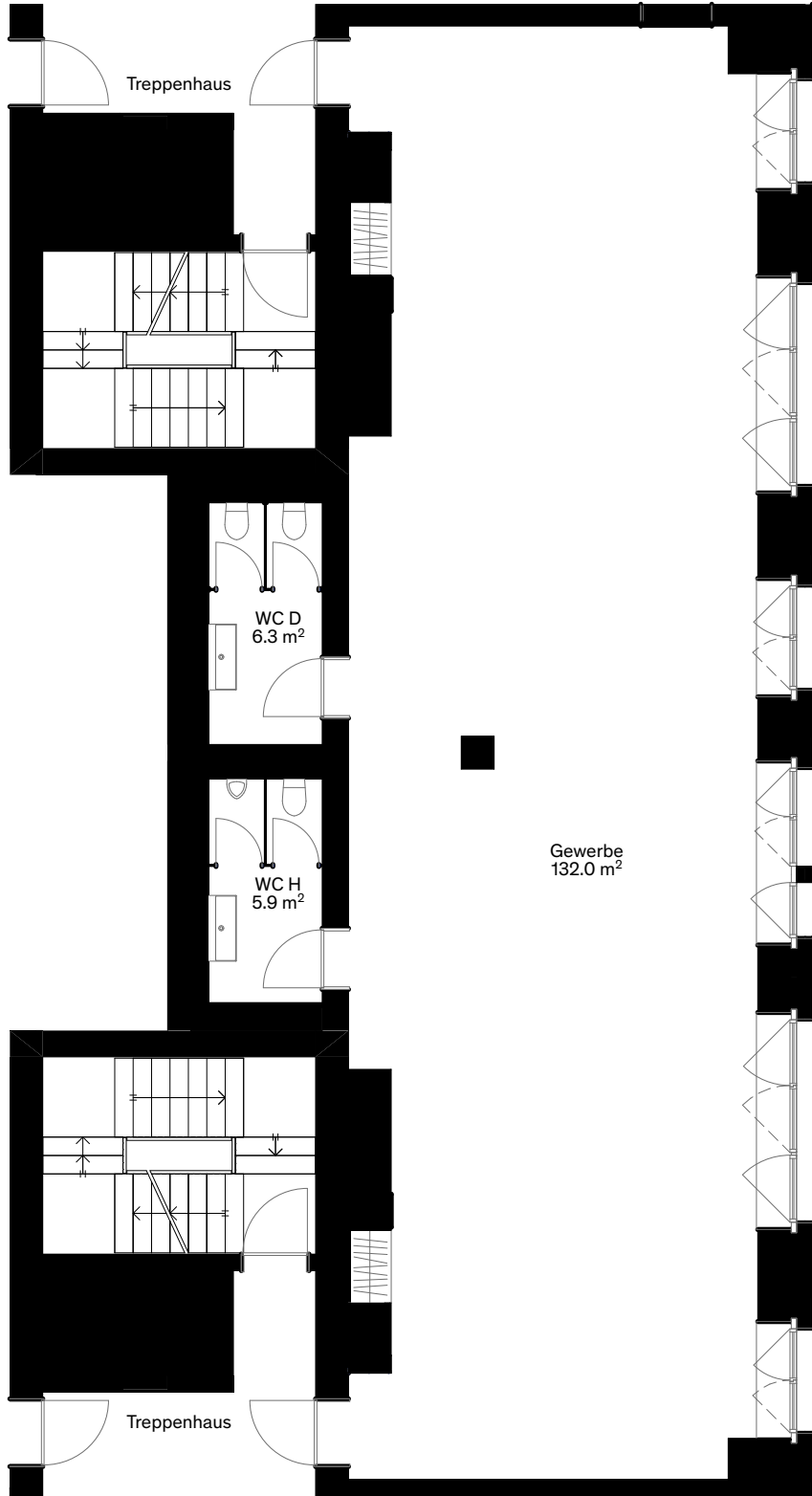
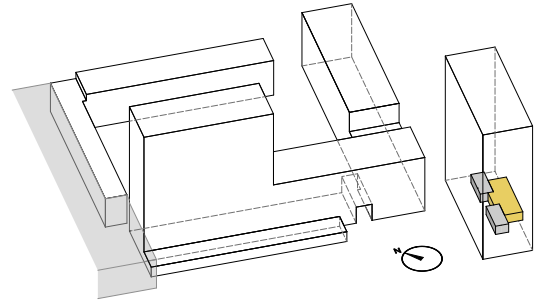

Etage 1. Obergeschoss
Fläche 172.9 m²
Raumhöhe 2.63 m

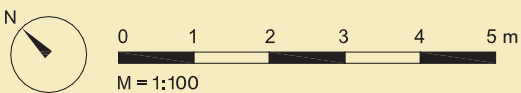
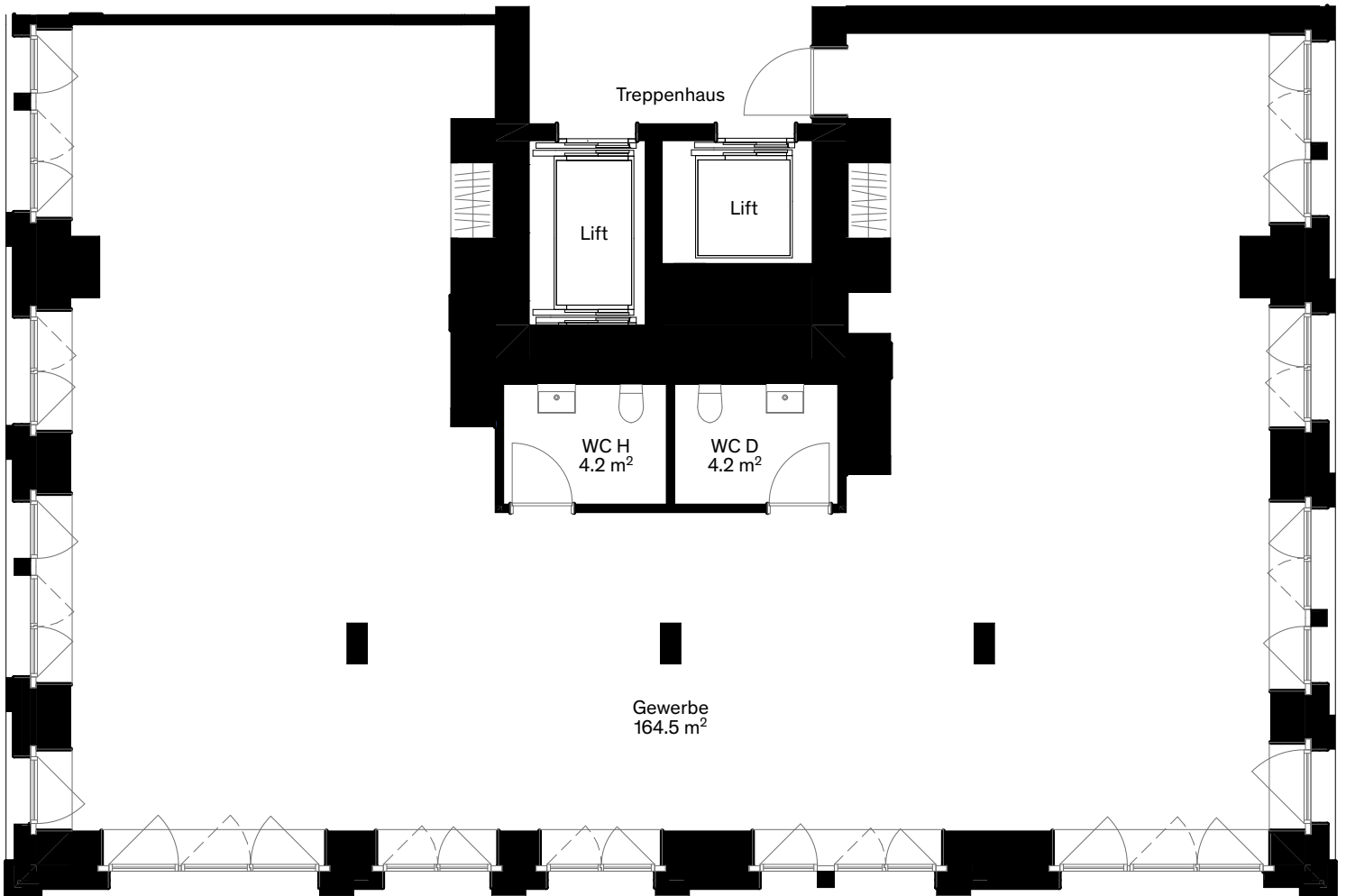
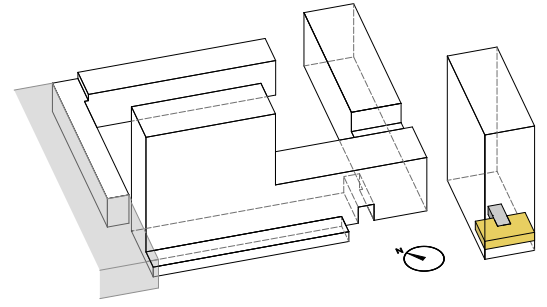

Etage 2. Obergeschoss
Fläche 206.4 m²
Raumhöhe 2.63 m

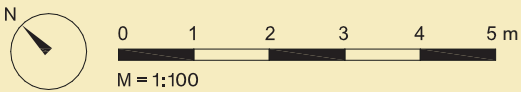
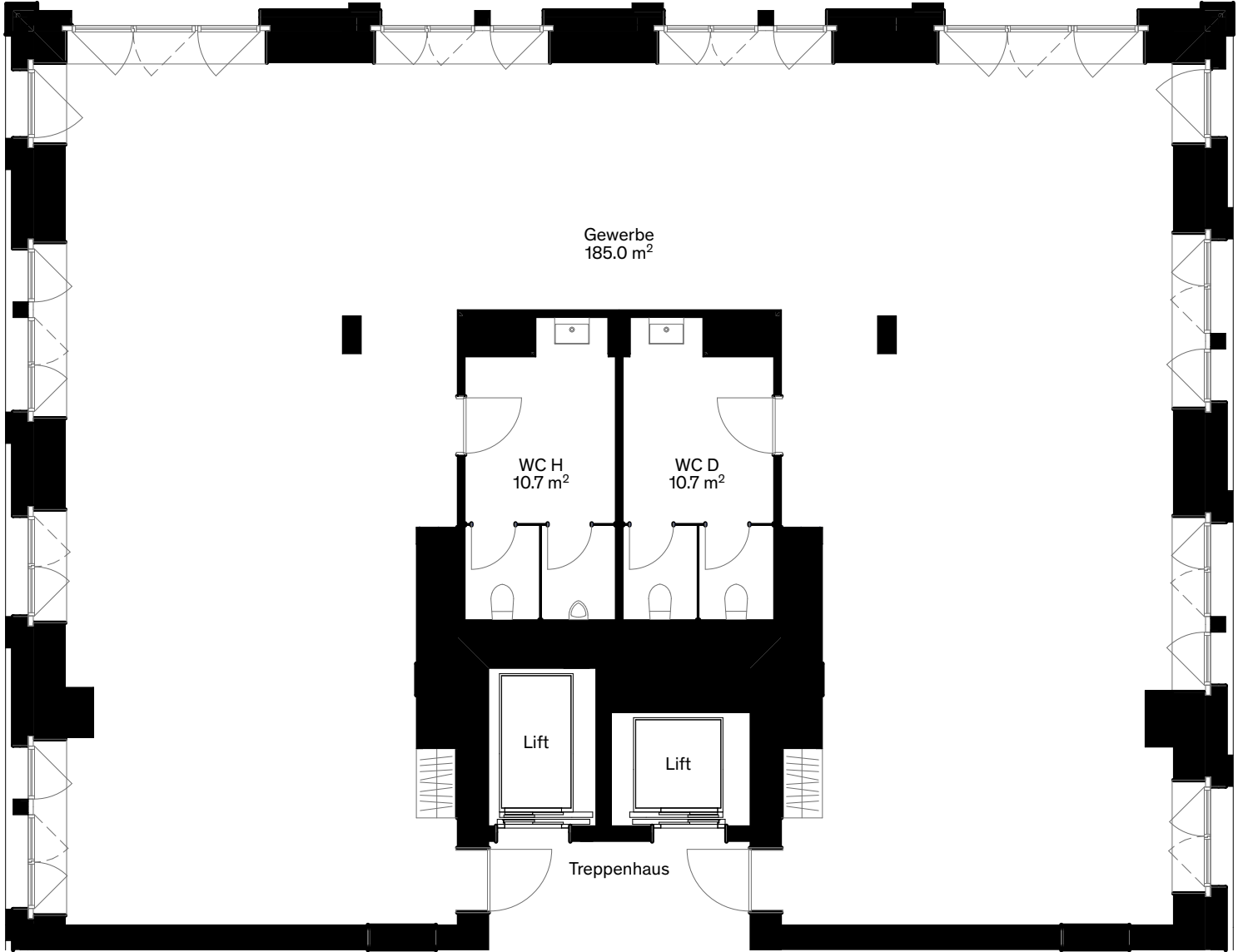
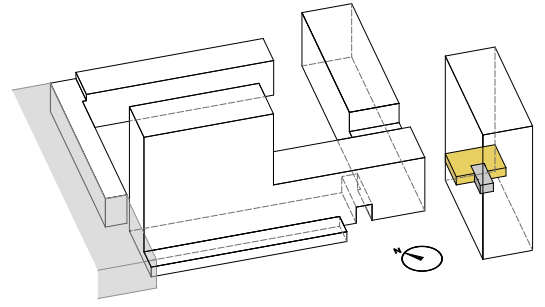

Haus B: Marmorì Turm
Gewerbefläche B1.02.2B

Sandackerstrasse 1b, 8957 Spreitenbach

Etage 2. Obergeschoss
Fläche 146.2 m²
Raumhöhe 2.63 m

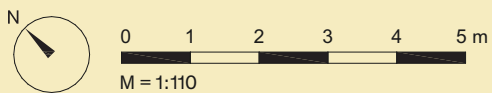
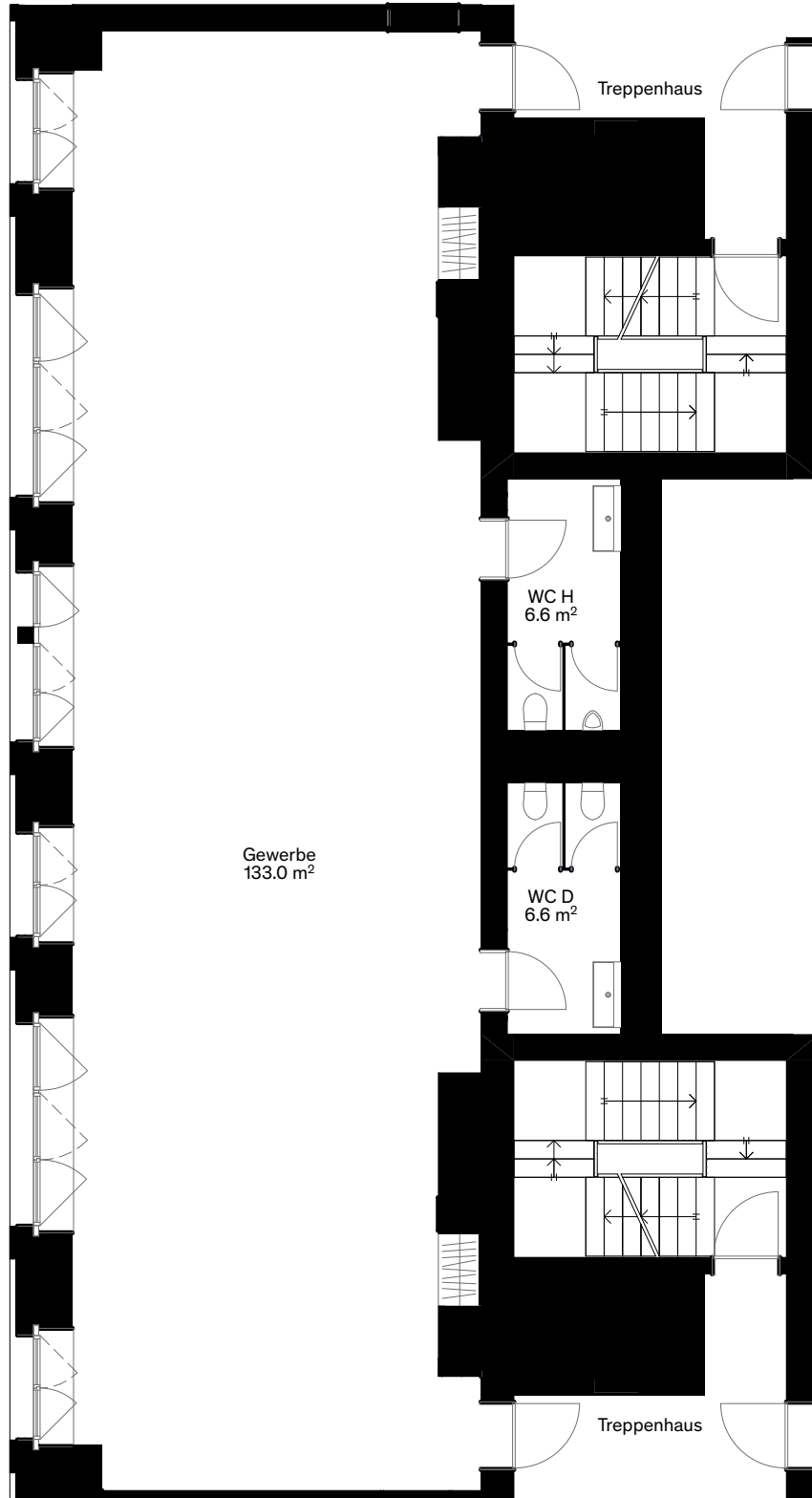
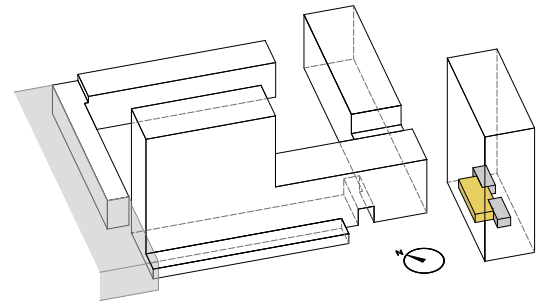

Alle Angaben, Pläne, Zeichnungen usw. sind unverbindlich.
Änderungen bleiben vorbehalten. Stand Mai 2023.

Intercity
Vermarktung

Intercity Vermarktung AG, Zollikerstrasse 141, 8008 Zürich
T +41 44 388 58 80, tivoli-garten@intercity.ch, www.tivoli-garten.ch

Haus B: Marmorì Turm
Gewerbefläche B2.02.2C

Sandackerstrasse 1a, 8957 Spreitenbach

Etage 2. Obergeschoss
Fläche 144.2 m²
Raumhöhe 2.63 m

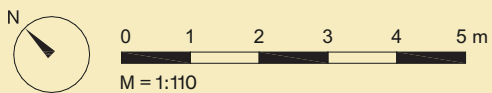
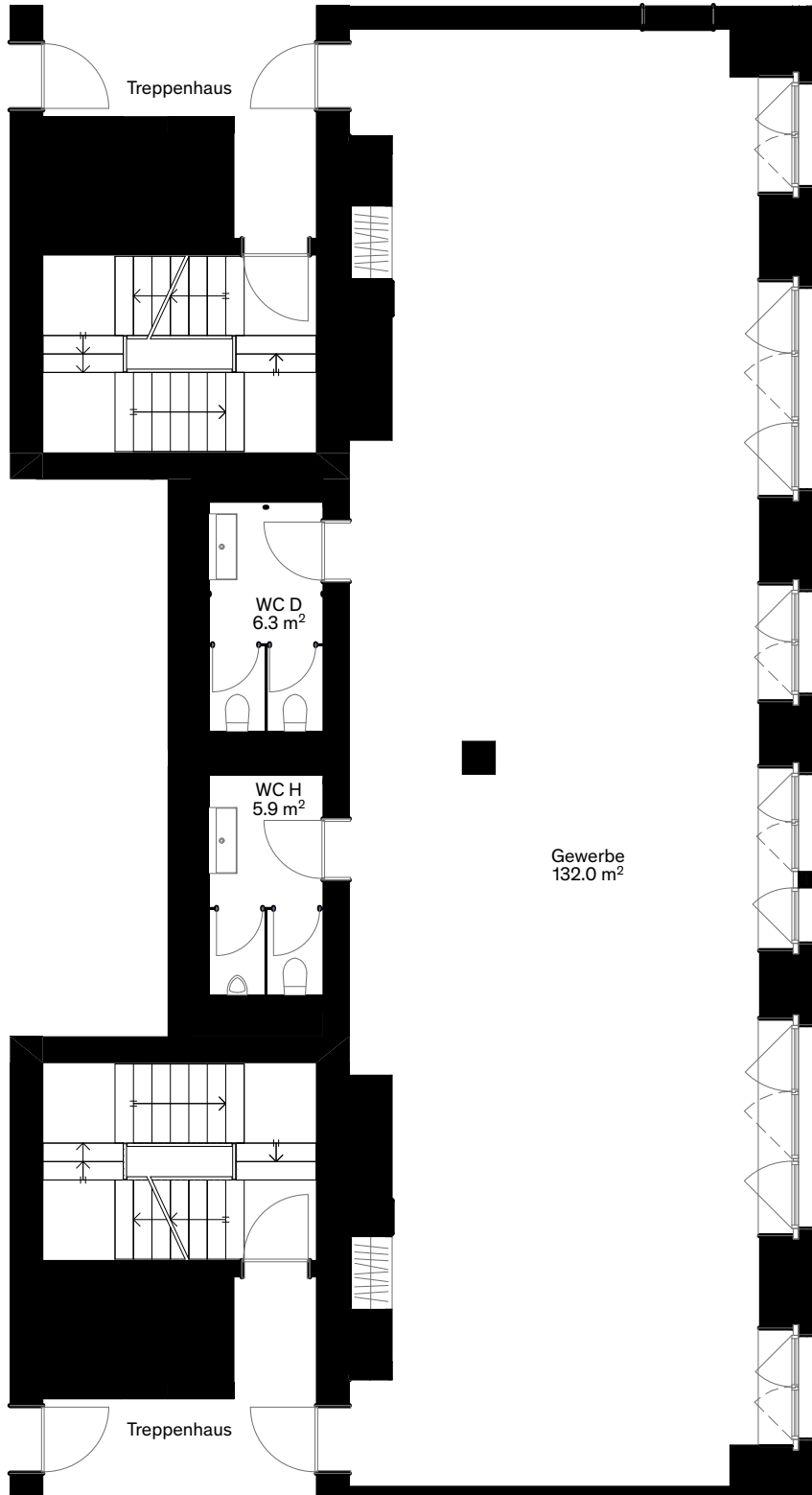
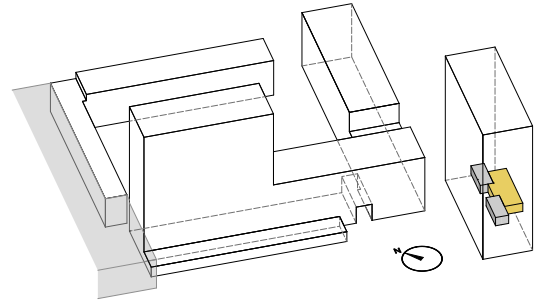

Alle Angaben, Pläne, Zeichnungen usw. sind unverbindlich.
Änderungen bleiben vorbehalten. Stand Mai 2023.

Intercity
Vermarktung

Intercity Vermarktung AG, Zollikerstrasse 141, 8008 Zürich
T +41 44 388 58 80, tivoli-garten@intercity.ch, www.tivoli-garten.ch

Etage 2. Obergeschoss
Fläche 172.9 m²
Raumhöhe 2.63 m

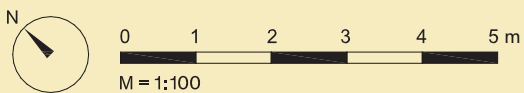
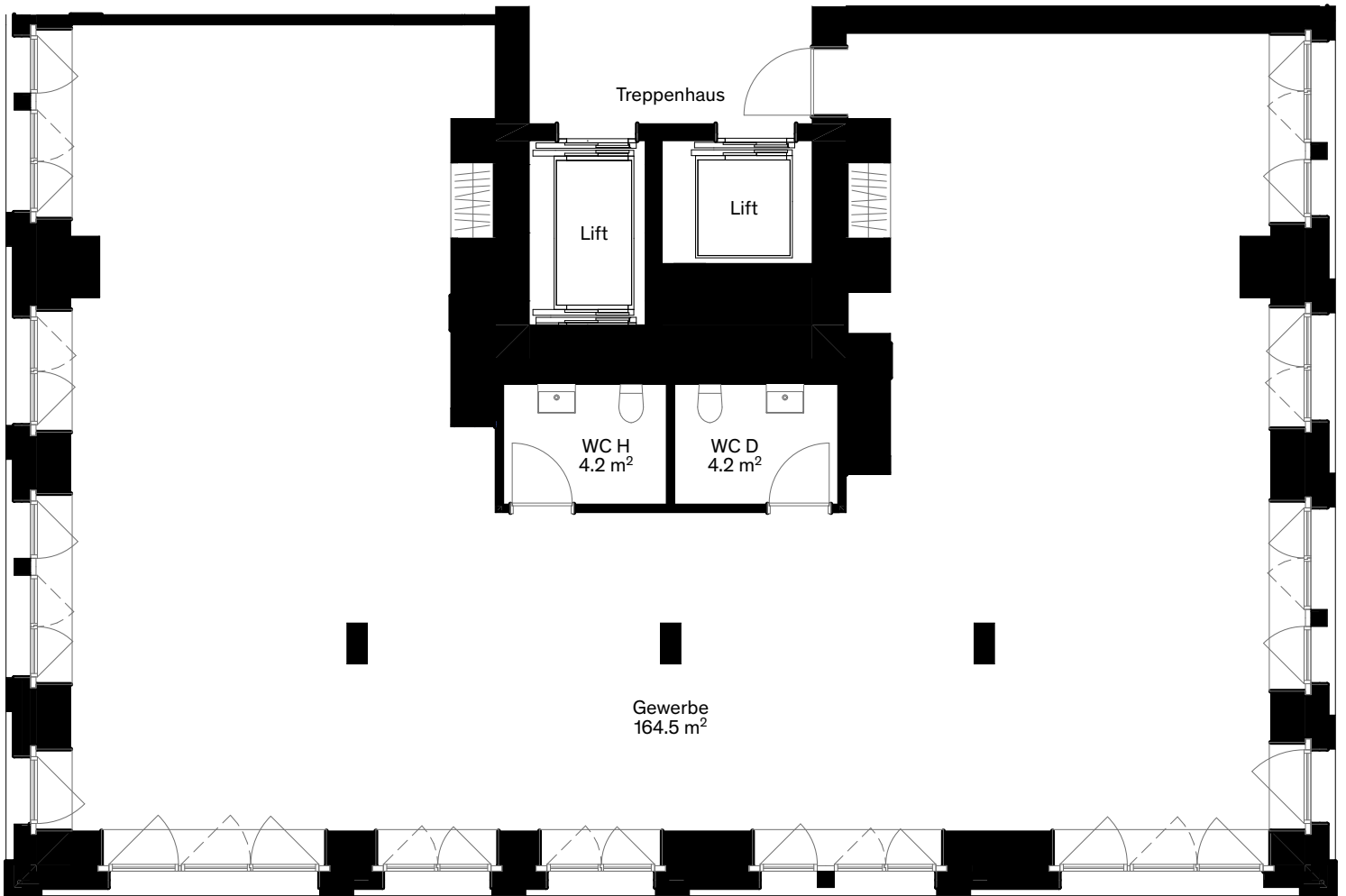
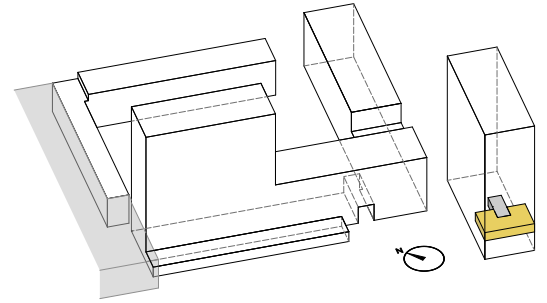

Haus C: Honeret
Gewerbefläche C0.FG.04

Sandackerstrasse 5a, 8957 Spreitenbach

Etage Fussgeschoss
Fläche 97.0 m²
Raumhöhe 3.95 m

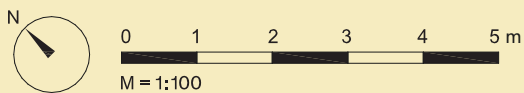
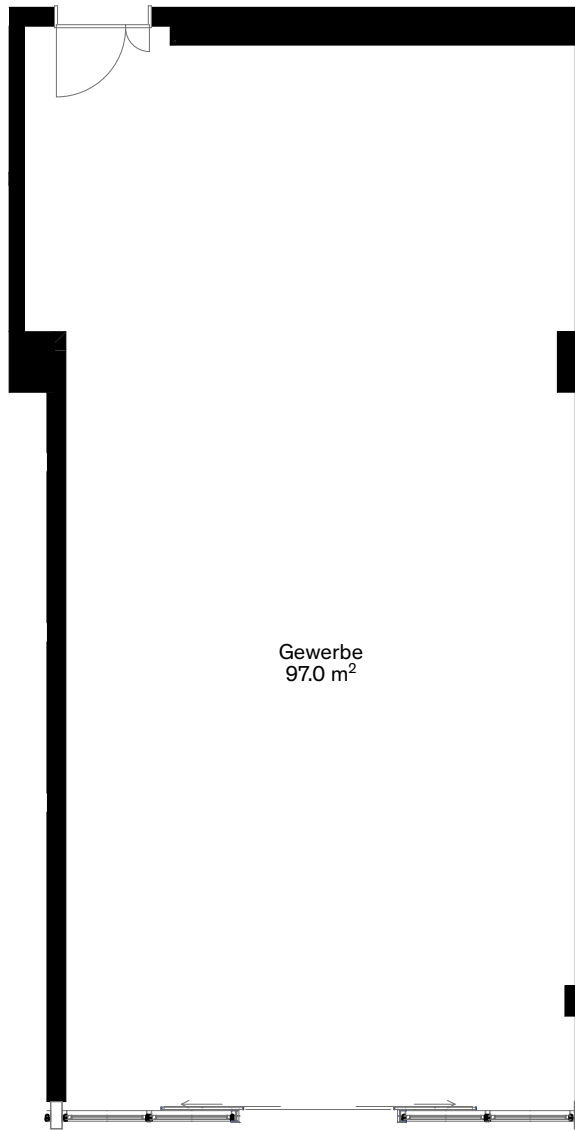
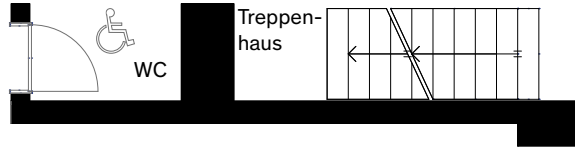
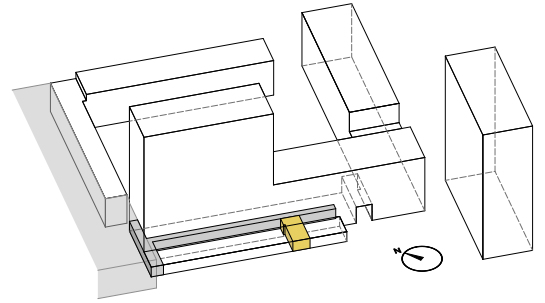

Etage Fussgeschoss
Fläche 100.0 m²
Raumhöhe 3.95 m

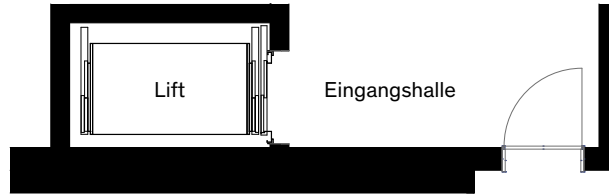
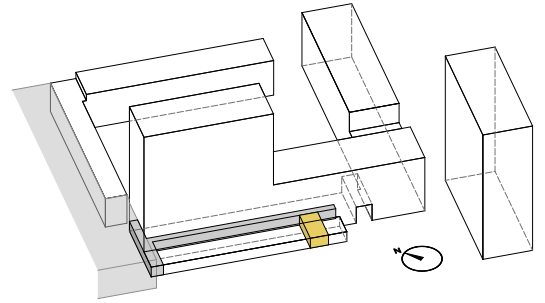

Korridor

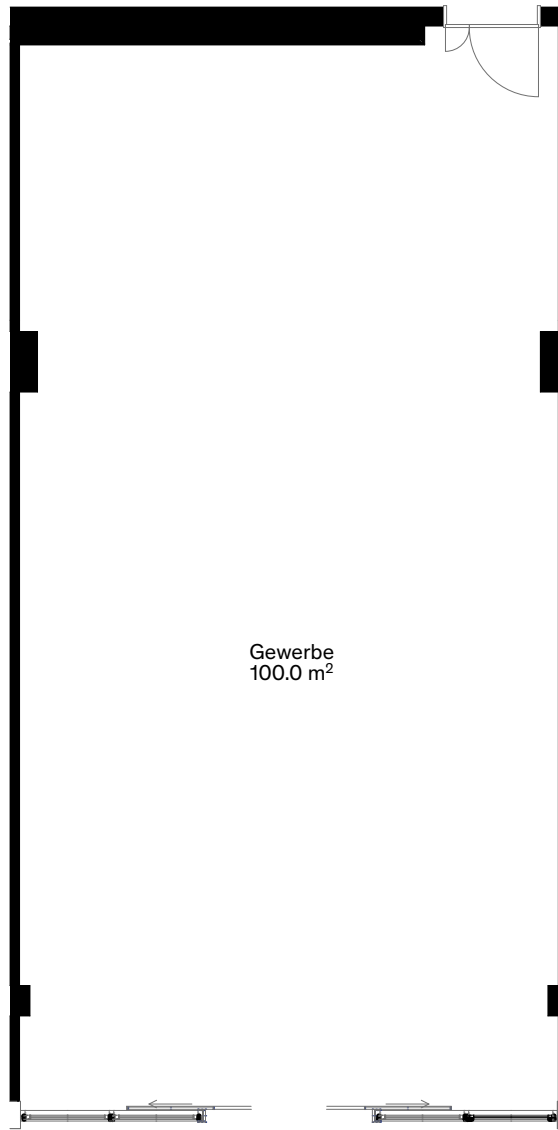

Gewerbe
100.0 m²

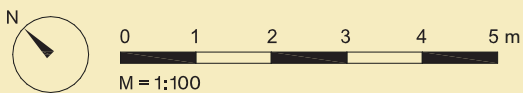

Etage Fussgeschoss
Fläche 94.5 m²
Raumhöhe 3.95 m

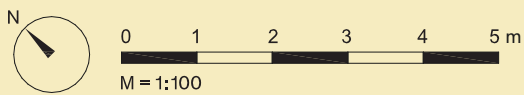
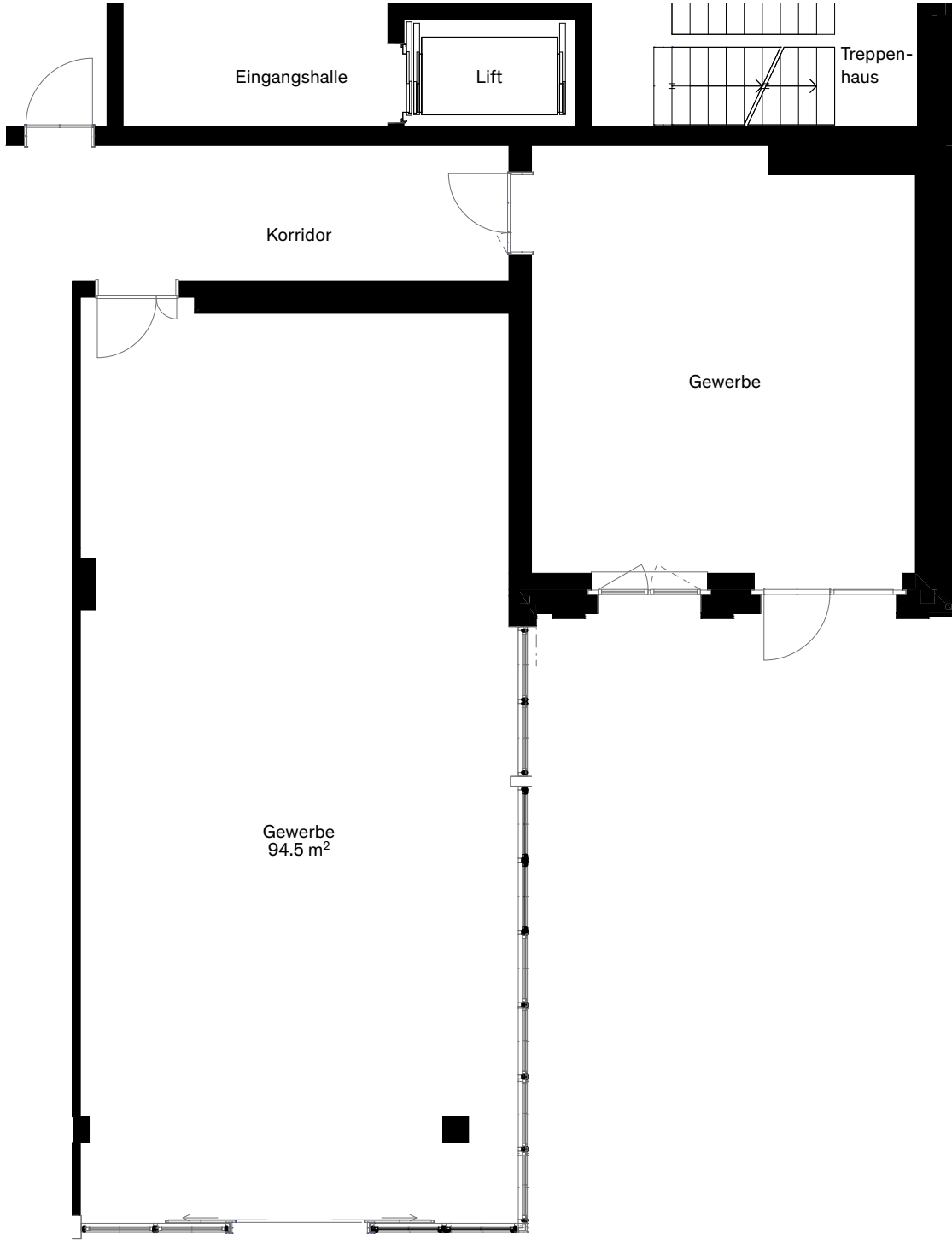
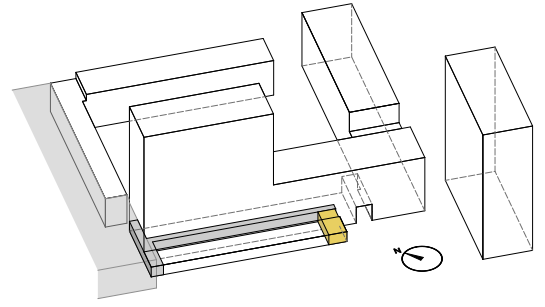

Alle Angaben, Pläne, Zeichnungen usw. sind unverbindlich.
Änderungen bleiben vorbehalten. Stand Mai 2023.

Etage Fussgeschoss
Fläche 39.0 m²
Raumhöhe 4.02 m

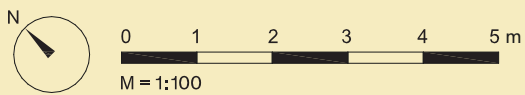
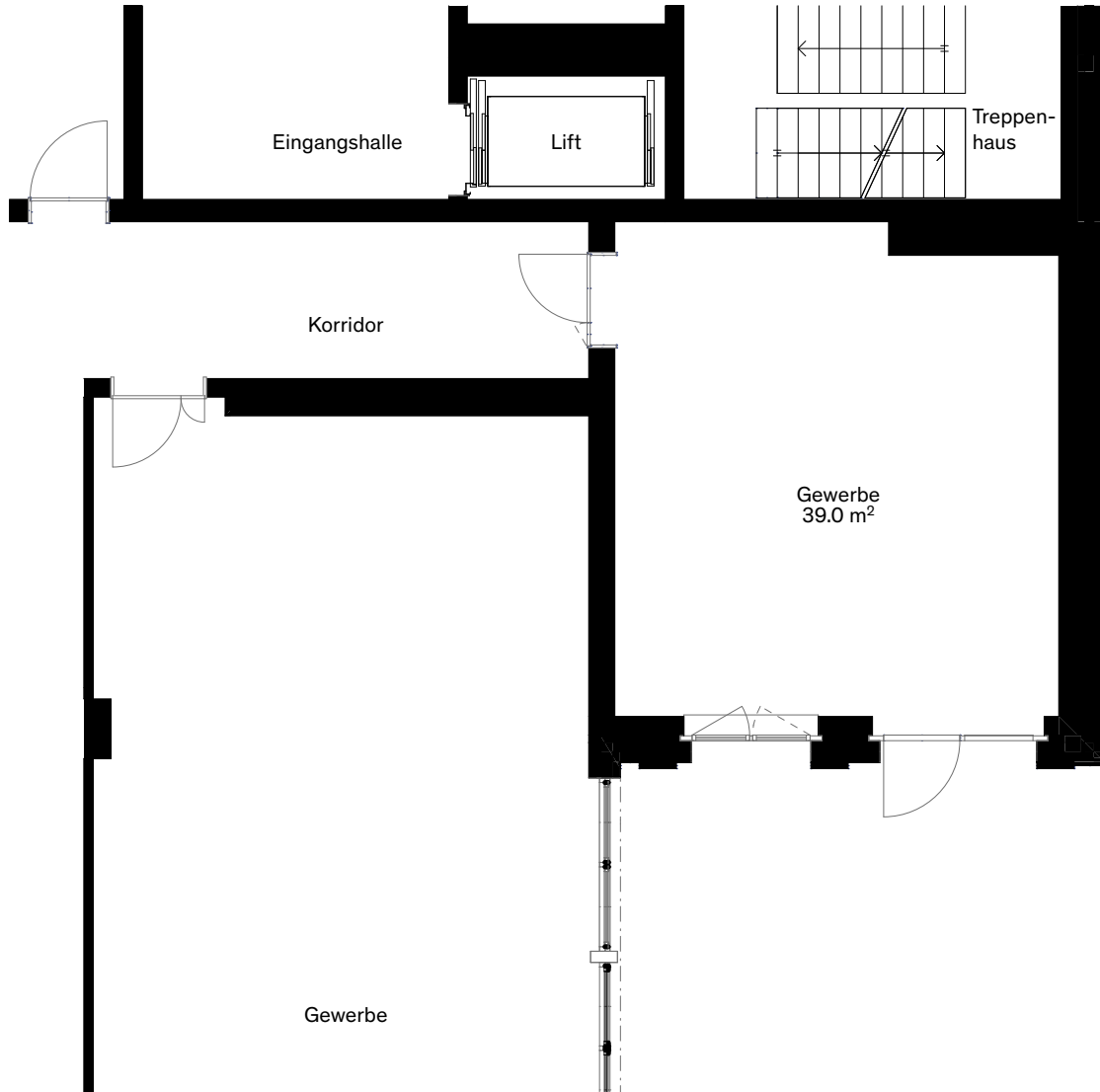
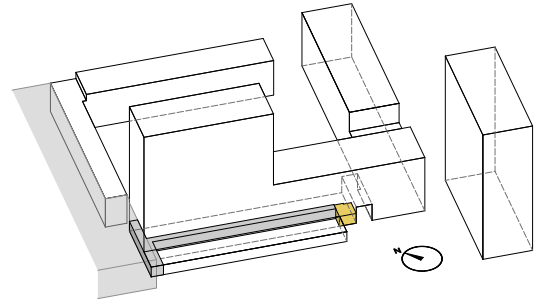

Etage Fussgeschoss
Fläche 284.5 m²
Raumhöhe 4.02 m

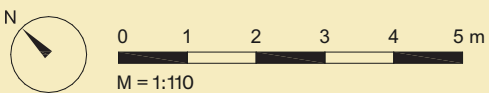
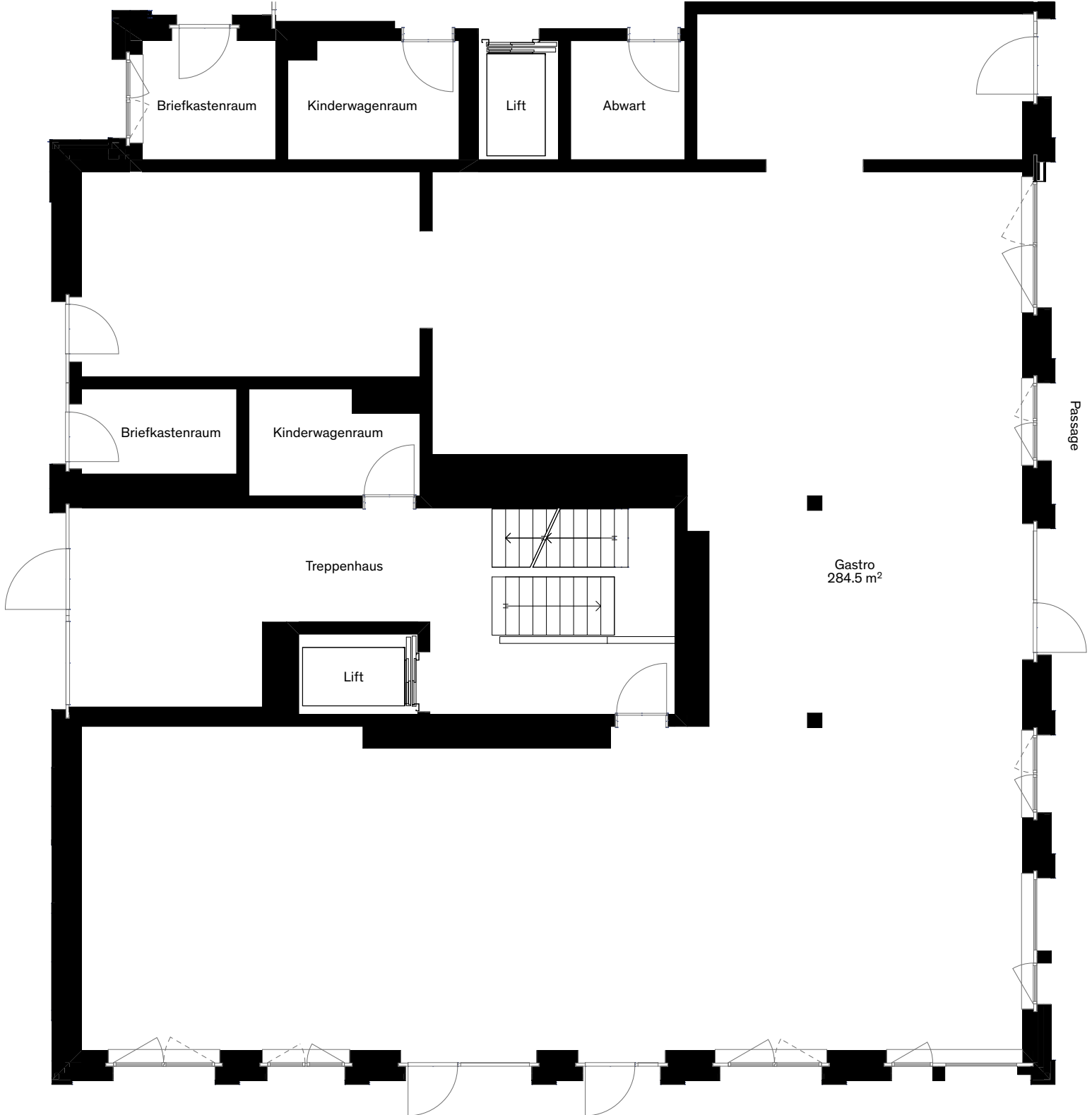
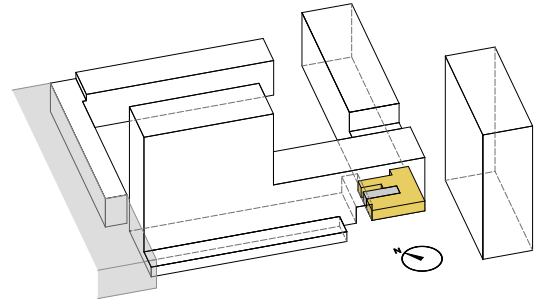

Etage Fussgeschoss
Fläche 99.0 m²
Raumhöhe 4.02 m

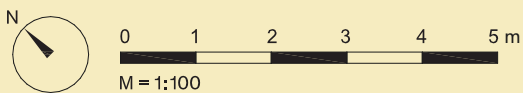
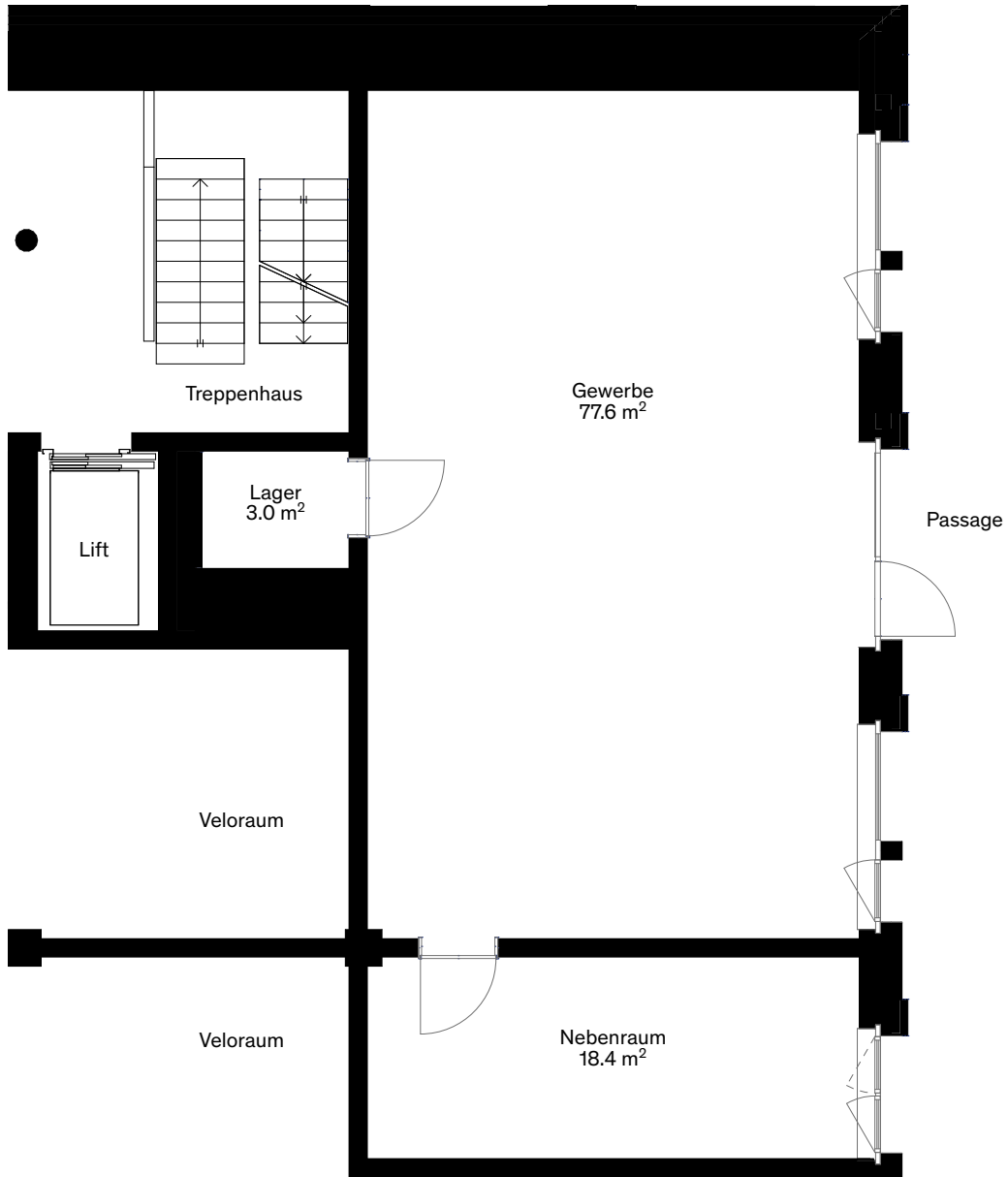
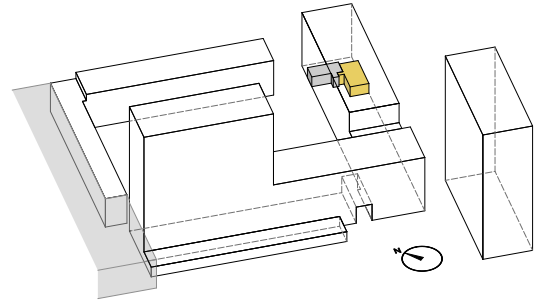

Etage Fussgeschoss
Fläche 51.5 m²
Raumhöhe 4.02 m

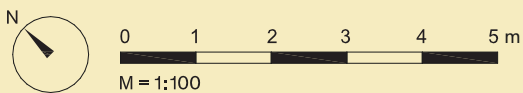
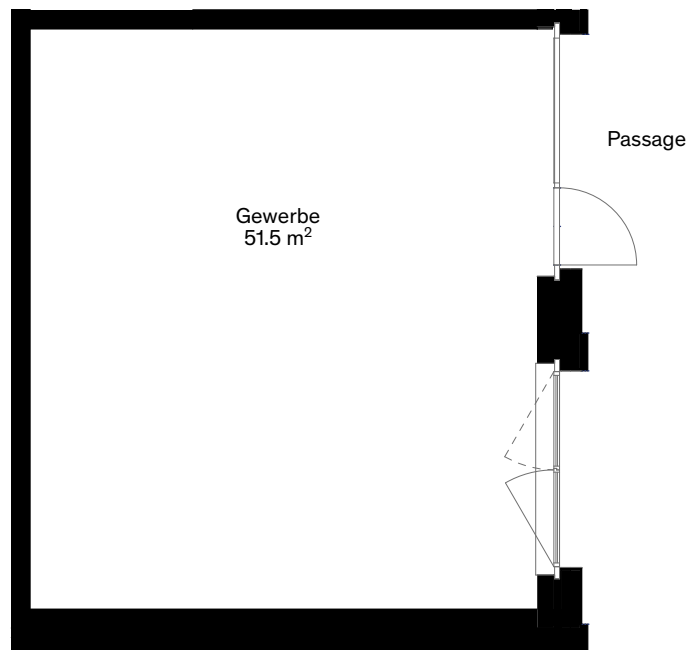
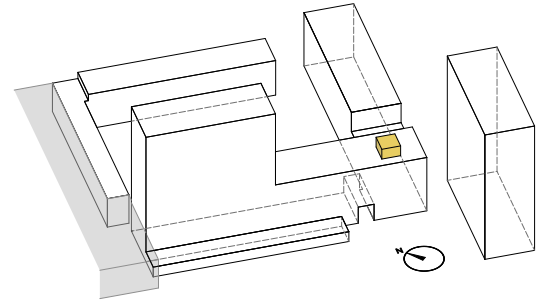

Etage Fussgeschoss
Fläche 51.0 m²
Raumhöhe 4.02 m

